

1
A502 NTS 400-600 506B

2
A502 NTS 400-600 509

3
A502 NTS 400-600 521

4
A502 NTS 400-600 601

5
A502 NTS 400-600 608

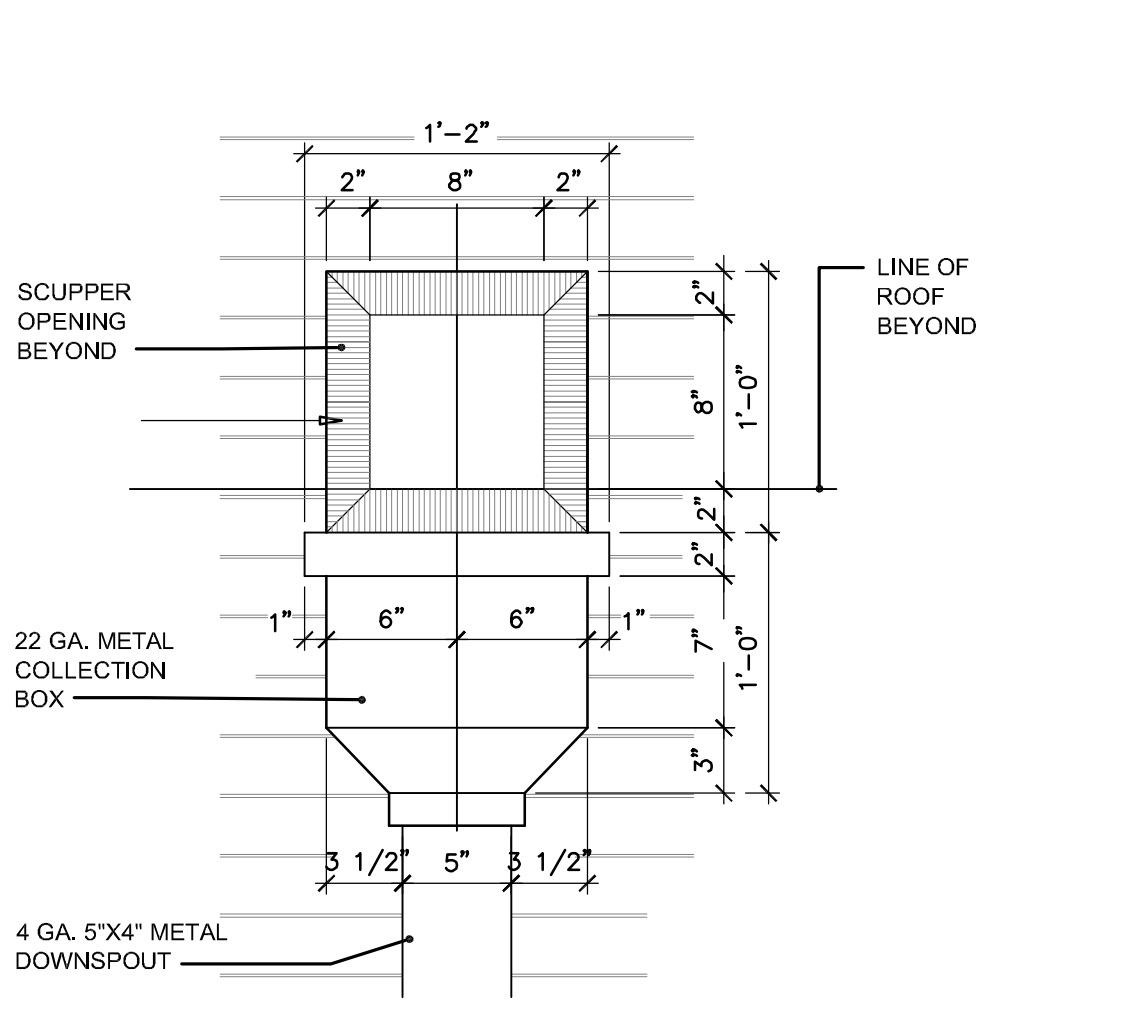
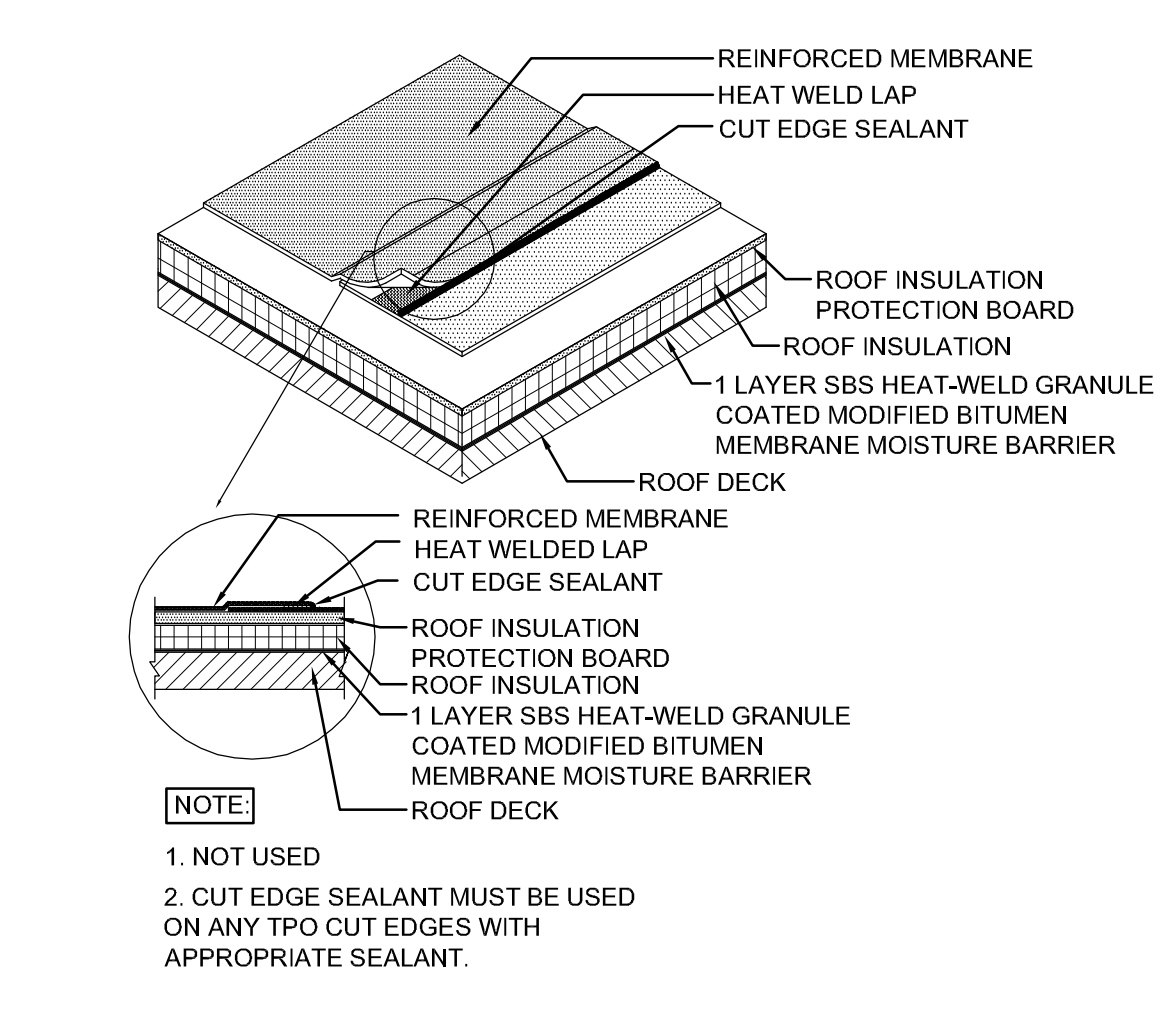

8
A502 NTS DET#

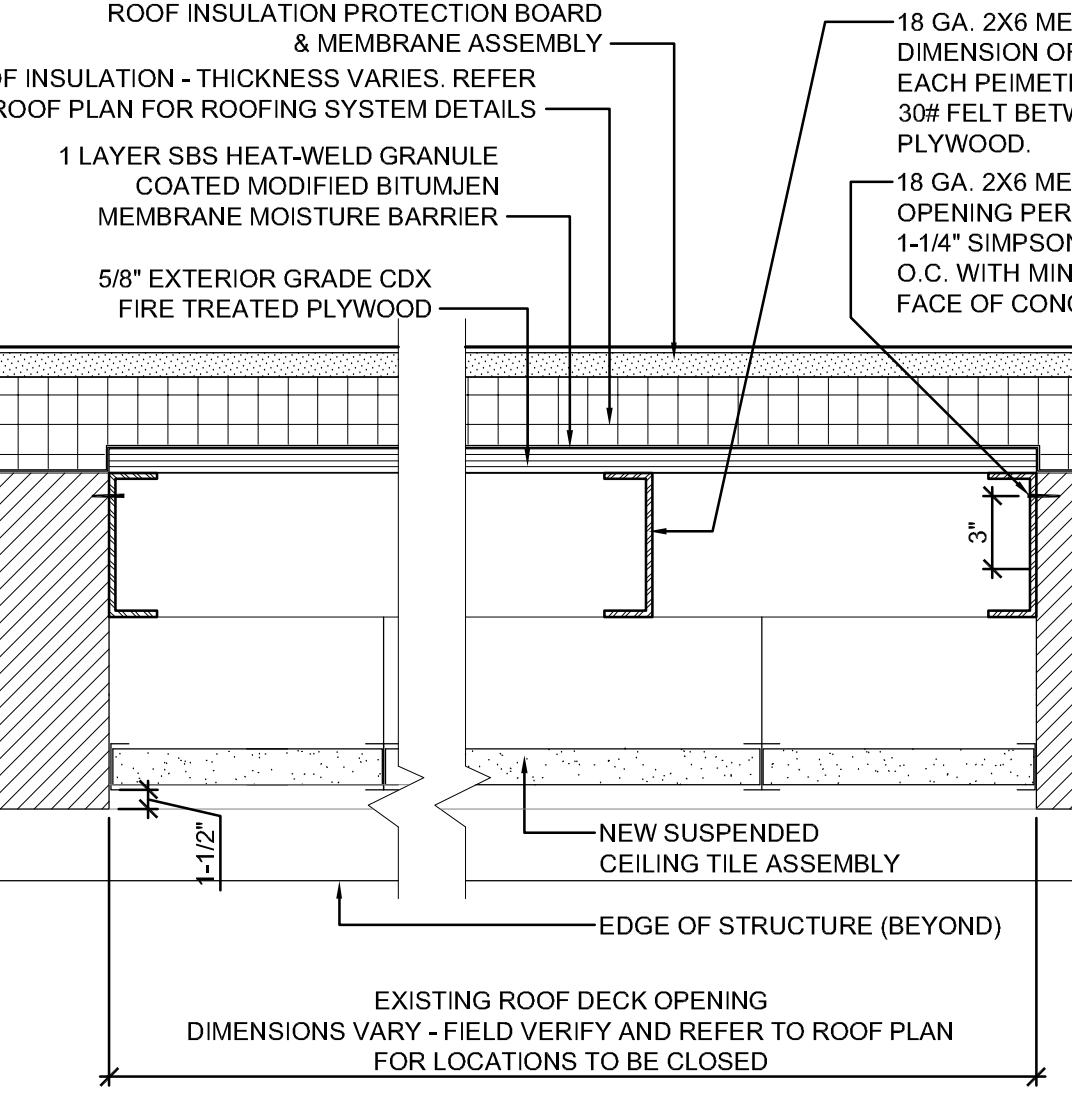

6
A502 NTS 400-600 115

7
A502 NTS DET1

8
A502 NTS DET#

9
A502 SCALE: 1-1/2"=1'-0" DET#

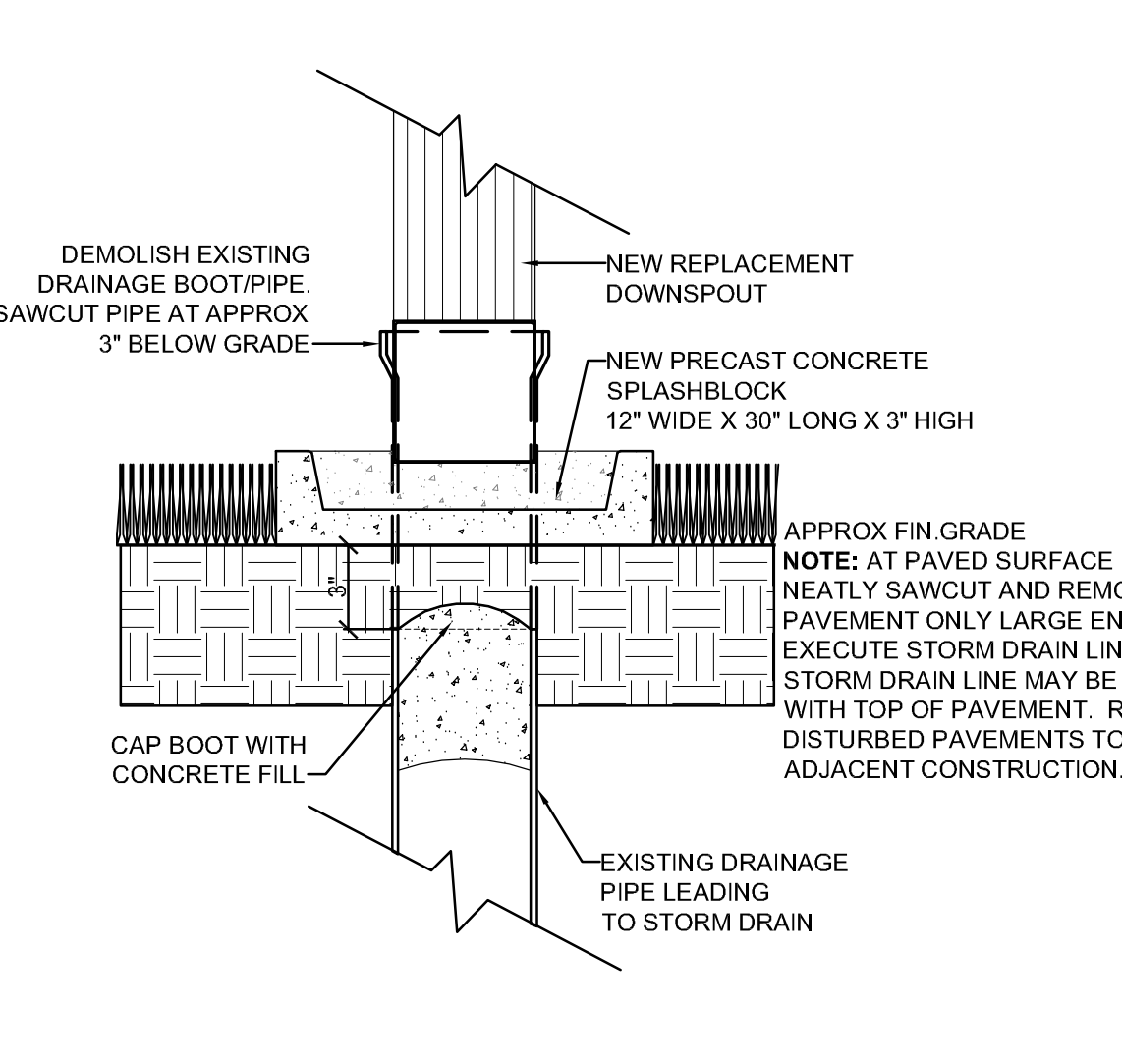
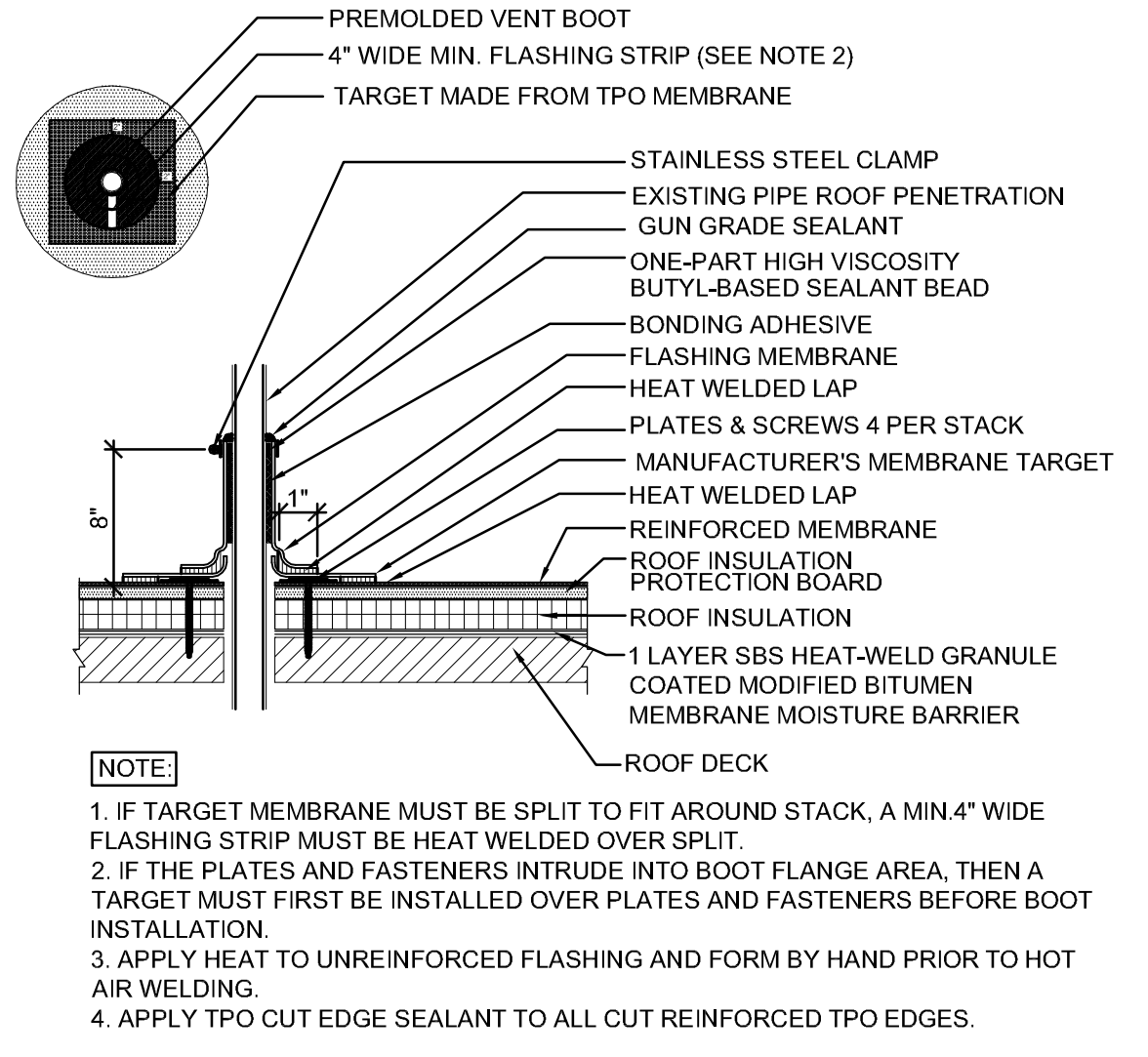

10
A502 NTS 400-600 507

11
A502 NTS

revisions
no. date

seal
JOHN R. PRUETT
REGISTERED ARCHITECT
NO. 20989
STATE OF TENNESSEE
11-18-2013

john pruetts architects
1869 madison ave.
memphis, tn 38104
(901) 721-9062
pruettsarchitects@bellsouth.net
www.pruettarchitects.com

ROOF REPLACEMENT
Peggy Edmiston Administration Building
1075 Mullins Station Road, Memphis, TN 38134

BID DOCUMENT SET
RFP # 14-011-24-A
sheet name
DETAILS
date
11.18.2013

A-502